

PRO·FORM

RESTORATION 5.1

Hydrotherapy Spa

Patent Pending

Model No. 831.210051

Serial No. _____

Write the serial number in the space above for reference. The serial number decal is on the frame behind the access cover.

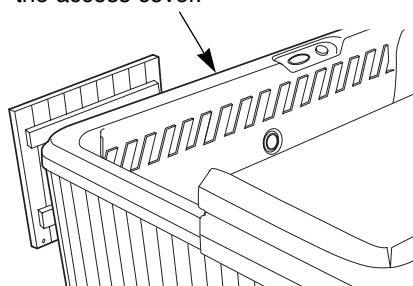

USER'S MANUAL

QUESTIONS?

PLEASE CALL DIRECT TO OUR TOLL-FREE CUSTOMER HOT LINE. The trained technicians on our customer hot line will provide immediate assistance, free of charge to you.

CUSTOMER HOT LINE:

1-800-999-3756

Mon.-Fri., 6 a.m.-6 p.m. MST



CAUTION

Read all precautions and instructions in this manual before using this equipment. Save this manual for future reference.

A pH testing kit (not included) is required for proper use and maintenance of this product. A pH testing kit can be purchased at any spa or pool supply store.

TABLE OF CONTENTS

IMPORTANT SAFETY INSTRUCTIONS	3
BEFORE YOU BEGIN	6
CHOOSING A LOCATION FOR THE HYDROTHERAPY SPA	7
SET-UP AND ASSEMBLY	8
WIRING THE RESTORATION 5.1	10
USING THE HYDROTHERAPY SPA	12
MAINTENANCE	16
TROUBLE-SHOOTING	20
PART LIST	22
EXPLODED DRAWING	23
ORDERING REPLACEMENT PARTS	Back Cover

LIMITED ONE YEAR MASSAGE SPA WARRANTY

ICON Health & Fitness, Inc. (ICON), warrants this product to be free from defects in workmanship and material, under normal use and service conditions, for a period of one (1) year from the date of purchase. Specifically covered under this warranty are the spa shell, the plumbing, the components, and the wood or tile exterior. This warranty extends only to the original purchaser. ICON's obligation under this warranty is limited to replacing or repairing, at ICON's option, the product at one of its authorized service centers. All products for which warranty claim is made must be received by ICON at one of its authorized service centers with all freight and other transportation charges prepaid, accompanied by sufficient proof of purchase. All returns must be pre-authorized by ICON. This warranty does not extend to any product or damage to a product caused by or attributable to freight damage, abuse, misuse, improper or abnormal usage, or repairs not provided by ICON authorized service personnel, to products used for commercial or rental purposes, or to products used as store display models. Specifically excluded are damages caused by or attributable to the following incidents: any damage to the wood exterior resulting from improper maintenance, or any damage to the wood or tile exterior attributable to freight mishandling; damage resulting from improper winterization; damage to the spa shell resulting from improper chemical treatment, damage to the spa shell resulting from exposure to extreme temperatures, or damage to the spa shell resulting from exposure to direct sunlight and ultraviolet rays while the spa is empty; damage to the pump, motor, plumbing, and components due to improper maintenance, chemical treatment, or exposure; damage resulting from failure to properly follow user's manual installation, operating, or maintenance instructions. Also excluded are consumable components, including but not restricted to headrests, filter cartridges, and light bulbs. No other warranty beyond that specifically set forth above is authorized by ICON.

ICON is not responsible or liable for indirect, special or consequential damages arising out of or in connection with the use or performance of the product or damages with respect to any economic loss, loss of or damage to property including water damage, loss of revenues or profits, loss of enjoyment or use, costs of removal, installation or other consequential damages of whatsoever nature. Some states do not allow the exclusion or limitation of incidental or consequential damages. Accordingly, the above limitation may not apply to you.

The warranty extended hereunder is in lieu of any and all other warranties and any implied warranties of merchantability or fitness for a particular purpose is limited in its scope and duration to the terms set forth herein. Some states do not allow limitations on how long an implied warranty lasts. Accordingly, the above limitation may not apply to you.

This warranty gives you specific legal rights. You may also have other rights which vary from state to state.

ICON HEALTH & FITNESS, INC., 1500 S. 1000 W., LOGAN, UT 84321-9813

IMPORTANT SAFETY INSTRUCTIONS

WARNING: TO REDUCE THE RISK OF DROWNING, ELECTRIC SHOCK, OR SERIOUS INJURY, READ THE FOLLOWING IMPORTANT PRECAUTIONS BEFORE USING THE RESTORATION 5.1.

READ AND FOLLOW ALL INSTRUCTIONS

1. It is the responsibility of the owner to ensure that all users of the hydrotherapy spa are adequately informed of all precautions.
2. Use the hydrotherapy spa only as described in this manual.
3. The hydrotherapy spa is intended for home use only. Do not use this product in any commercial, rental, or institutional setting.
4. Use the hydrotherapy spa only on a level surface. Do not use the hydrotherapy spa on carpet or other materials that could be damaged by moisture. Do not use the hydrotherapy spa on rough or sharp surfaces such as gravel or wood chips.
5. The hydrotherapy spa will weigh approximately 2000 pounds when it is filled with water. Be sure that the location you select for the hydrotherapy spa will support this weight, plus the weight of the occupants.
6. Inspect and tighten all parts often; replace any worn or missing parts immediately.
7. **DANGER—Risk of injury:** Do not remove or alter the covers on the suction fittings. Never operate the hydrotherapy spa if the suction guard is missing or broken. If you need to replace a suction fitting, be sure that the flow rate of the replacement is compatible. Keep hair and body away from the suction guard. Do not allow long hair to float freely in the water; long hair should be restrained with a bathing cap.
8. **IMPORTANT:** Do not allow the hydrotherapy spa to be exposed to direct sunlight when it is empty. The surface of the spa shell can reach temperatures as high as 150°F in a matter of minutes if exposed to the sun while it is empty. These high temperatures can cause significant damage, such as blistering of the shell surface and warping of the spa shell. Any damage caused by sun exposure is not covered under warranty.
9. Do not bring any object into the hydrotherapy spa that could damage the spa shell.
10. Never insert any object into any opening.
11. Do not use breakable containers near or in the hydrotherapy spa.
12. Do not sit on the spa cover or place objects on it. It is not designed to support weight.
13. Remove any water or debris which may collect on the spa cover.
14. Keep children under 12 and pets away from the hydrotherapy spa when it is not in use.
15. Keep all chemicals away from children and pets.
16. The pH and chemical balance of the water must be maintained as explained in this manual (see pages 12 and 17). Failure to do so may cause injury to users or damage to the spa, and will void the warranty.
17. Individuals with infections and open sores or wounds should not use the hydrotherapy spa. Bacteria thrive in warm and hot water. Always keep your spa disinfected and maintain the proper chemical balance.
18. Shower before and after using the hydrotherapy spa. This will remove any deodorant, perspiration, or body oils which could contaminate the water. Showering after will remove any residual chemicals and will also remove any residual bacteria which may have been in the spa.
19. **DANGER—**The hydrotherapy spa must be wired directly into a 240 volt power source (see **WIRING THE RESTORATION 5.1** on page 10). Only a qualified electrician can perform this procedure. No other appliance should be on the same circuit. Replace the power cord immediately if damaged.

20. **DANGER**—If you will be using the hydrotherapy spa outside, do not bury the power cord; you should also keep the power cord away from lawn mowers, hedge trimmers, and other similar equipment.
21. **WARNING**—The hydrotherapy spa must be wired directly into a 240 volt power source equipped with a Ground Fault Circuit Interrupter (GFCI). The GFCI must be tested before each use. To test the GFCI, press the “test” button while the spa is running. The spa should shut off. Press the “reset” button. The spa should resume normal operation. If the spa continues to run after the “test” button is pressed, then the GFCI is damaged. Do not use the hydrotherapy spa until the GFCI has been repaired or replaced by a qualified electrician.
22. Keep all electrical appliances such as radios, telephones, televisions, and lights at least five feet (1.52 meters) away from the water.
23. A wire connector is provided on the pump motor of this unit to connect a minimum No. 8 AWG (804 mm²) solid copper conductor between this unit and any metal equipment, electrical enclosure made of metal, metal water pipes, or conduit within five feet (1.52m) of the unit.
24. **DANGER**—Risk of electric shock: Do not set up the hydrotherapy spa within five feet of any metal objects or surfaces. As an alternative, you may use the hydrotherapy spa within five feet of metal objects if each metal object is permanently connected to the wire connector on the pump motor of this unit by a minimum No. 8 AWG (804 mm²) solid copper conductor (see instruction 24).
25. Do not operate the pump motor when the spa is empty. The pump motor may be seriously damaged if it is operated without water circulating. The cut-off valves must always be open when using the spa (see step 2 on page 8).
26. **DANGER**—To reduce the risk of drowning:
- Never use the hydrotherapy spa alone;
 - Children should not use the hydrotherapy spa unless they are supervised by an adult;
 - Keep pets away from the hydrotherapy spa at all times;
 - Always replace and lock the spa cover when the hydrotherapy spa is not in use.
27. **DANGER**—Risk of drowning: Exercise extreme caution to prevent unauthorized and unsupervised use of the hydrotherapy spa by children. Children must always be supervised.
28. **WARNING**—To reduce the risk of injury: The water temperature should never exceed 104°F (40°C). Temperatures between 100°F (38°C) and 104°F (40°C) are considered to be safe for healthy adults. However, if you plan to remain in the hydrotherapy spa for more than 10 to 15 minutes, a lower temperature is recommended. Lower temperatures are also recommended for children. Children should not be allowed to swim under the surface of the water in the spa.
29. **WARNING**—To reduce the risk of injury: Always use an accurate thermometer to determine the water temperature before using the hydrotherapy spa.
30. **WARNING**—To reduce the risk of injury: Pregnant women should consult with their physician before using the hydrotherapy spa. Pregnant women should not use the hydrotherapy spa if the water temperature is above 100°F (38°C); the unborn child could be seriously harmed. This is especially important during the first 90 days of the pregnancy.
31. **DANGER**—To reduce the risk of drowning: Prolonged immersion in the hydrotherapy spa may cause hyperthermia, a dangerous condition which occurs when the internal body temperature rises several degrees above the normal body temperature of 98.6°F. The symptoms of hyperthermia are nausea, dizziness, drowsiness, and fainting. Effects include: a lack of awareness, inability to perceive heat or danger, and a greater risk of drowning due to a loss of consciousness. Special note: Individuals suffering from hyperthermia may be unable to realize that they must exit the hydrotherapy spa, and they also may be physically unable to do so.
32. **WARNING**—To reduce the risk of drowning: Do not use the hydrotherapy spa if you are under the influence of alcohol or drugs. Heat from the water, in conjunction with alcohol or drugs can cause unconsciousness.
33. Do not use the hydrotherapy spa immediately after strenuous exercise.

34. **WARNING**—To reduce the risk of injury or drowning: Consult your physician about possible side-effects of any medications you may be taking before using the hydrotherapy spa. Heat from the water, in conjunction with some medications may cause drowsiness and increase the risk of drowning. Others can effect blood pressure, heart rate, and circulation.

35. **WARNING**—To reduce the risk of injury: It is especially important for persons over the age of 35 or persons with pre-existing health problems, such as obesity, heart disease, high or low blood pressure, circulatory problems, or diabetes to consult their physician before using this product.

36. If you feel pain or dizziness at any time while using the hydrotherapy spa, discontinue use and contact a physician.

37. The included warning sign must be posted where all users of the spa can see and read it (see **POSTING THE WARNING SIGN** on page 15).

38. Never use soft water when filling the hydrotherapy spa. Soft water is extremely corrosive to the metal parts within the spa unit and can lead to pump and spa failure.

39. **WARNING DECAL PLACEMENT:** Locate the decals shown below and familiarize yourself with this information.

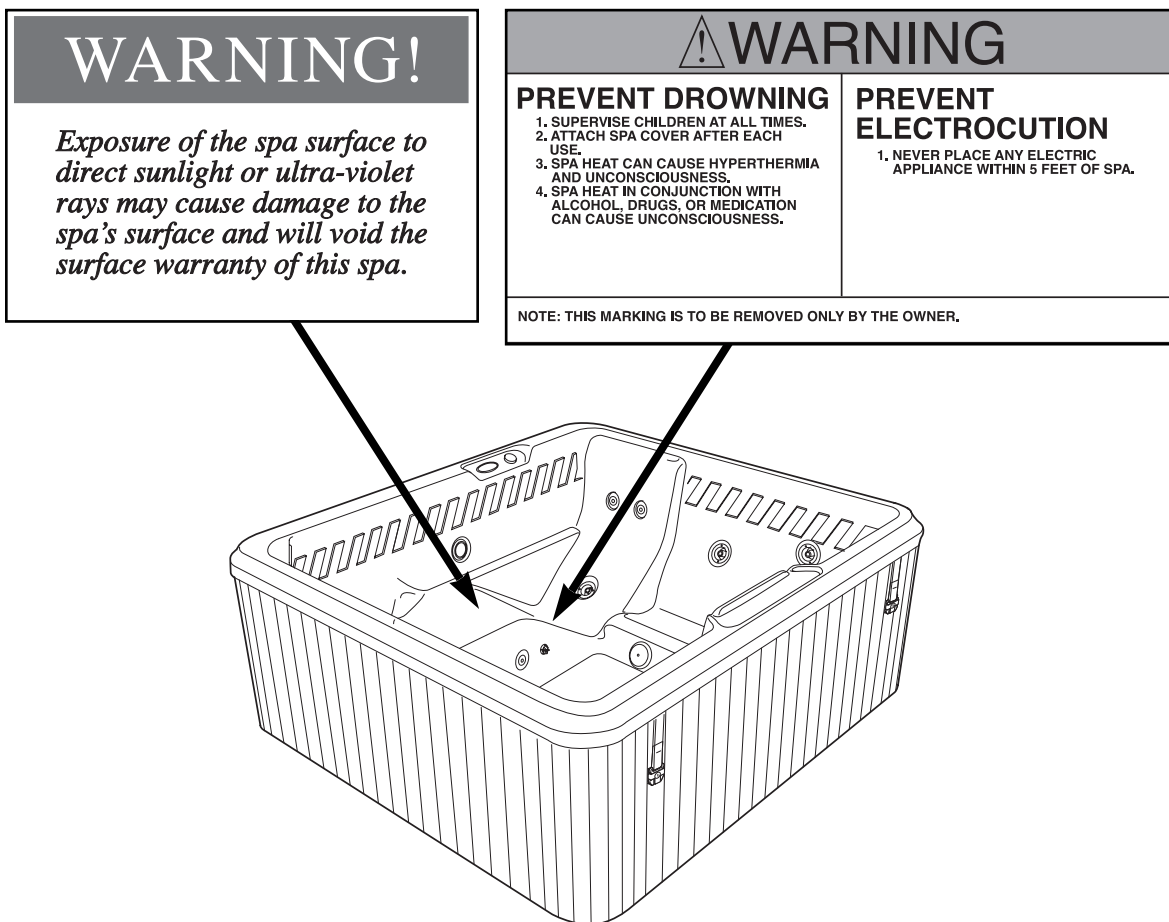

WARNING: Read all instructions before using the hydrotherapy spa. ICON assumes no responsibility for personal injury or property damage sustained by or through the use of this product.

SAVE THESE INSTRUCTIONS

BEFORE YOU BEGIN

Thank you for selecting the innovative PROFORM® RESTORATION 5.1 hydrotherapy spa. The RESTORATION 5.1 hydrotherapy spa offers the features and quality of a traditional hot tub at an affordable price. Best of all, the RESTORATION 5.1 hydrotherapy spa provides the benefits of hydrotherapy in the comfort and privacy of your own home. Hydrotherapy is a proven method for soothing tired muscles after exercise or for relieving the stress of a busy life. The warm environment stimulates blood flow which is essential in the healing process. The powerful massage action created by the jets further eases tension and stress throughout the body. The RESTORATION 5.1 hydrotherapy spa gives you the specialized treatment you need to feel your best.

For your safety and benefit, read this manual carefully before using the PROFORM® RESTORATION 5.1. If you have additional questions, please call our Customer Service Department toll-free at 1-800-999-3756, Monday through Friday, 6 a.m. until 6 p.m. Mountain Time (excluding holidays). To help us assist you, please note the product model number and serial number before calling. The model number is 831.210051. The serial number can be found on a decal attached to frame inside the spa (see the front cover of this user's manual).

Before reading further, please familiarize yourself with the parts that are labeled in the drawing below.

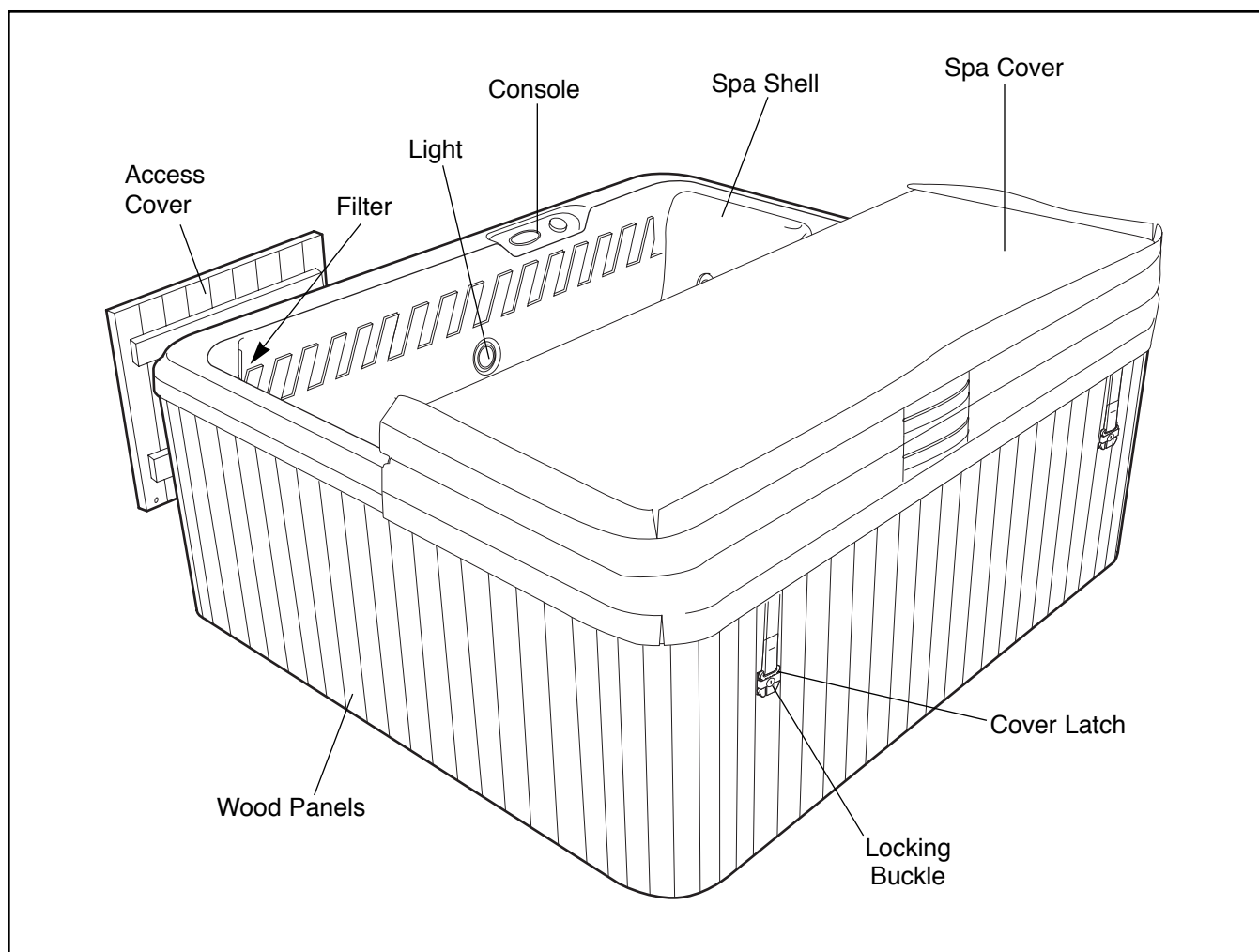

CHOOSING A LOCATION FOR THE HYDROTHERAPY SPA

There are many factors to consider when choosing a location to set up the hydrotherapy spa. These factors vary depending on whether you use the hydrotherapy spa inside or outside. We have listed several factors you may wish to consider as you decide where you want to use the hydrotherapy spa.

If you set up the hydrotherapy spa inside:

1. The hydrotherapy spa will increase the level of humidity in your home. The location you choose should be well ventilated. You may need to install a ventilation fan or use a dehumidifier.
2. The hydrotherapy spa should be close to a source of water.
3. Do not use the hydrotherapy spa on carpet or other material that may be damaged by moisture. We recommend that you place the hydrotherapy spa on a water- and stain-resistant, non-slip surface with a floor drain for any water that may splash from the hydrotherapy spa.
4. Be sure that the location you choose is stable. It must be able to support the weight of the hydrotherapy spa when it is filled with water, plus the weight of the occupants. The hydrotherapy spa weighs approximately 2000 pounds when filled with water.
5. Do not use the hydrotherapy spa above a finished living area, due to the risk of water damage.
6. Be sure that there is room around the hydrotherapy spa to permit servicing of the unit. The dimensions of the spa are: 5'10"W x 6'4"L x 2'6"H. You should allow for this size when choosing the location.
7. The hydrotherapy spa is not designed for in-floor installation. However, it is compatible with a deck system that is built flush with the top of the spa, provided you leave access to the motor for service.
8. Be sure to note any other considerations, such as aesthetics or privacy concerns, which may affect the safety or enjoyment of using the hydrotherapy spa.

If you set up the hydrotherapy spa outside:

1. You should check your local building codes concerning the use of outdoor spas.
2. The hydrotherapy spa should be close to a source of water.
3. We recommend that you place the hydrotherapy spa on a water- and stain-resistant, non-slip surface. Do not use the hydrotherapy spa on rough or sharp surfaces such as gravel or wood chips.
4. Be sure that the location you choose is stable. It must be able to support the weight of the hydrotherapy spa when it is filled with water, plus the weight of the occupants. The hydrotherapy spa weighs approximately 2000 pounds when filled with water.
5. Think about environmental factors, such as rain, wind, shade, sunlight, and so forth.
6. You should be able to monitor the use of the hydrotherapy spa from your home, to prevent unauthorized use by children. You may want to enclose the spa with a fence and self-latching gate to prevent unauthorized use.
7. Be sure that there is room around the hydrotherapy spa to permit servicing of the unit. The dimensions of the spa are: 5'10"W x 6'4"L x 2'6"H. You should allow for this size when choosing the location.
8. The hydrotherapy spa is not designed for in-ground installation. However, it is compatible with a deck system that is built flush with the top of the spa, provided you leave access to the motor for service.
9. Be sure to note any other considerations, such as aesthetics or privacy concerns, which may affect the safety or enjoyment of using the hydrotherapy spa.

SET-UP AND ASSEMBLY

Before beginning assembly, carefully read the following information and instructions:

- Place all parts in a cleared area and remove the packing materials from the spa shell; do not dispose of the packing materials until assembly is completed and the spa is in operation.
- Assembly requires two people.
- During assembly, make sure that all parts are oriented as shown in the drawings.

- Read each assembly step before you begin.
- Tighten all parts as you assemble them, unless instructed to do otherwise.

ASSEMBLY REQUIRES THE FOLLOWING TOOLS (not included):

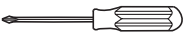
- **One (1) phillips screwdriver** 
- **You may also need some soap or wax.**

1. **Before beginning assembly, be sure that you have read and understand the information on the previous two pages.**

Remove the four access cover screws from the access cover. Remove the access cover from the Spa Unit (15) by sliding the access cover down and pulling the bottom of access cover away from the Spa Unit. **Be careful not to damage the spa shell.**

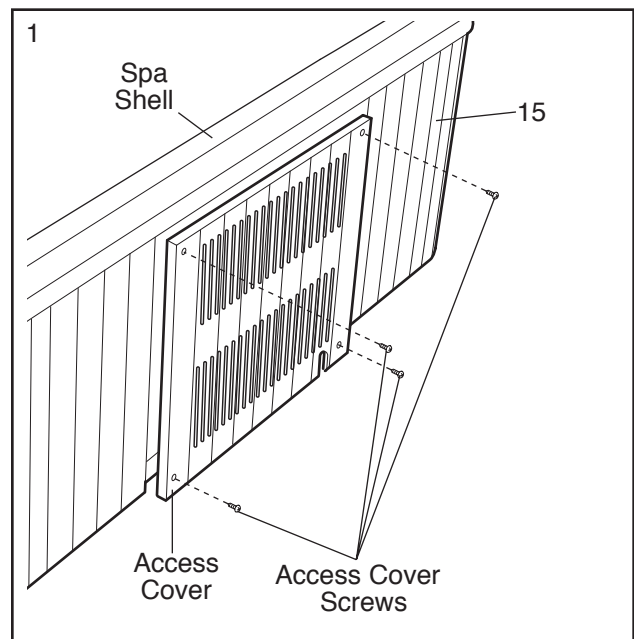

2. Locate and check the position of the cut-off valves. Occasionally the valves will be closed at the factory during manufacturing. The cut-off valves must be open for proper spa operation. To open the valves, hold one of the handles and turn the handle until you can pull it out to the open position. Open the other valve in the same manner. **WARNING: THE MOTOR WILL BE DAMAGED IF IT IS OPERATED WITH THE CUT-OFF VALVES CLOSED.**

Close the valve knob on the drain hose. Thread the cap onto the drain hose. Thread the drain plug into the Pump Motor (13). Tighten the pump fittings.

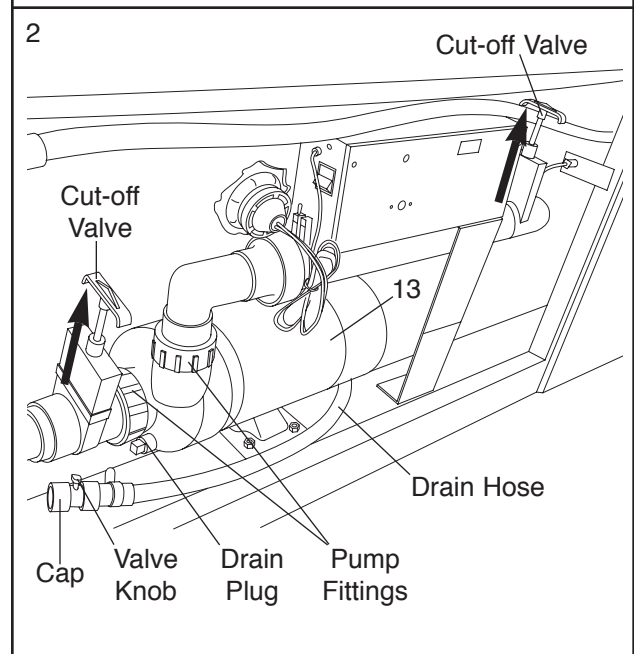

3. Place the Spa Cover (18) over the spa. **Be sure that the Spa Cover is properly centered.**

Snap a Buckle (2) onto each of the four latches on the Spa Cover (18).

See the inset drawing. Position one of the Buckles (2) on the wood panels on the Spa Unit (15). Hold the Buckle in place so the strap on the Spa Cover (18) is tight. (Note: It may be easier to position the Buckle if a second person holds the strap on the opposite side of the Spa Cover tight.) **The Spa Cover must be tight. Do not place the Buckle over one of the grooves in the wood panels.** Remove the latch. Attach the Buckle to the side of the spa with two Buckle Screws (1). **Note: It may be helpful to use a drill with a 1/16" drill bit to make starter holes in the wood panels. You may also want to apply a little soap or wax to the screw threads.**

Attach the other three Buckles (2) to the Spa Unit (15) in the same manner.

Remove the Spa Cover (18) from the Spa Unit (15).

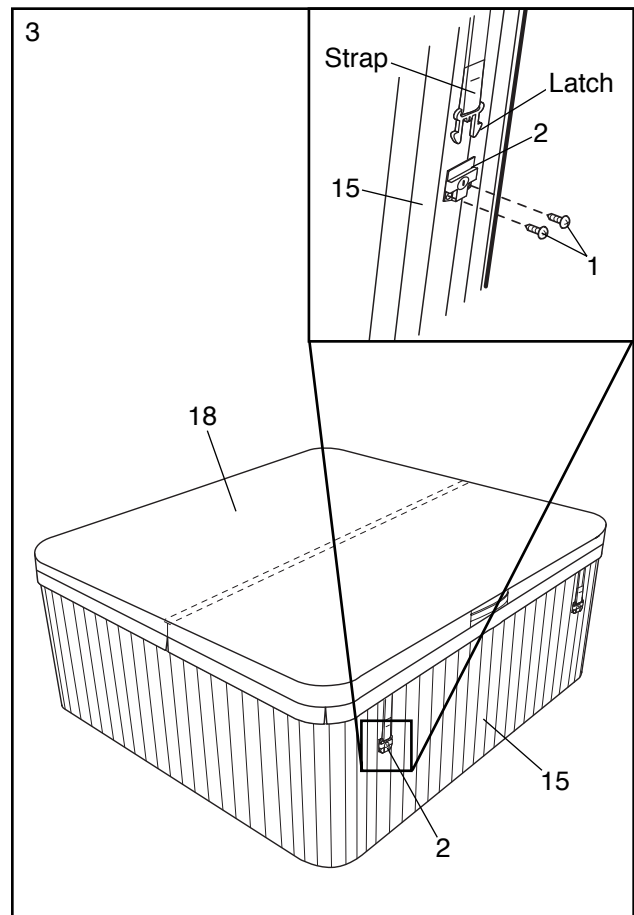

4. The RESTORATION 5.1 is designed to operate with a 240 volt power source and must be wired directly to a 240 volt ground fault circuit interrupter (GFCI) installed in your home. **This procedure must be performed by a qualified electrician.** Before you have the spa wired, be sure that it is in the position you want, and that it can be easily serviced, if needed.

The procedure is outlined (see WIRING THE RESTORATION 5.1 on page 10), as a reference for the qualified electrician. **Under no circumstances should this procedure be performed by someone other than a qualified electrician.**

5. After a qualified electrician has wired the spa to a 240 volt power source, wipe out the spa shell using a damp cloth. Remove the two warning decals (not shown) from the spa shell. Before you fill the spa, be sure that it is in the position you want, and that it can be easily serviced, if needed. Once the spa is filled with water, it must be drained to be moved.

Using a garden hose or other clean water source, begin filling the spa. **Do not use soft water.** The water temperature does not matter; however, if you use warm or hot water, the spa will be ready to use sooner. Fill the spa, until the water is about four inches below the console. **Do not overfill the spa.**

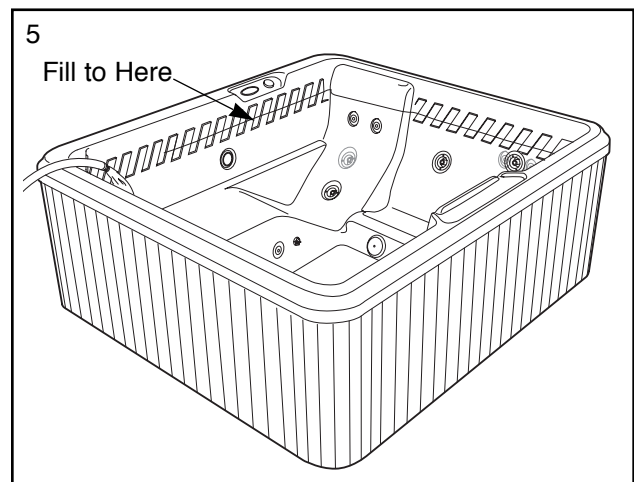

WIRING THE RESTORATION 5.1

The RESTORATION 5.1 is designed to operate with a 240 volt AC power source; it must be wired by a qualified electrician directly into a 240 volt AC GFCI in your home. The steps below are intended to be used as a reference for the qualified electrician who wires your spa and installs the 240 volt AC GFCI in your home. **WARNING: Only a qualified electrician should perform this procedure.**

1. Remove the two indicated Control Unit Screws (19) and the two Small Star Washers (8) from the cover on the Control Unit (14). Fold the cover down.

Route the 240 volt AC power cord through the indicated opening on the right side of the Control Unit (14).

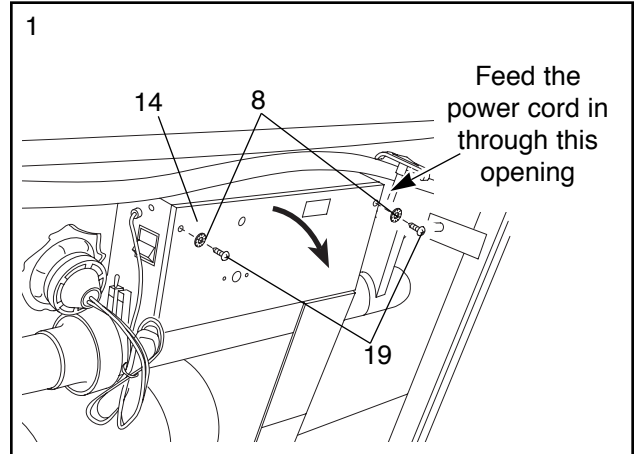

2. Attach the 240 volt AC power cord to the indicated wires inside the Control Unit (14) as shown in the diagram to the right.

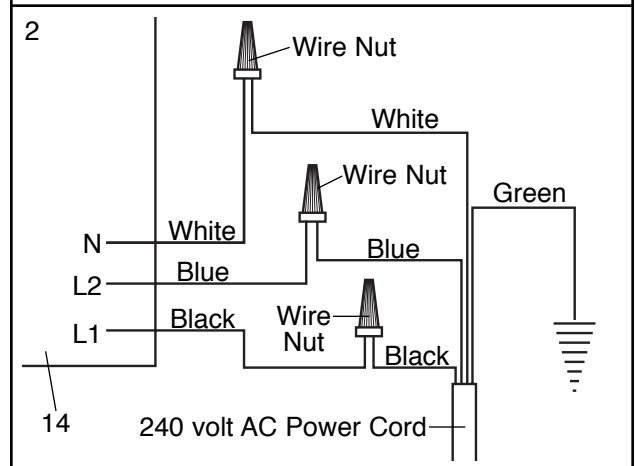

3. Determine if the 240 volt AC power supply in the home is a 30 amp supply or a 40 amp supply.

If the home power supply is a 30 amp supply, go to step 4.

If the home power supply is a 40 amp supply, go to step 5.

4. For a 30 amp, 240 volt AC power supply, set the jumper J1 to pins 2 and 3 on the power board and leave the other jumpers at the factory settings, as shown at the right. At 30 amps, there is not enough amperage to operate the heater and the pump at high speed simultaneously. **Go to step 6.**

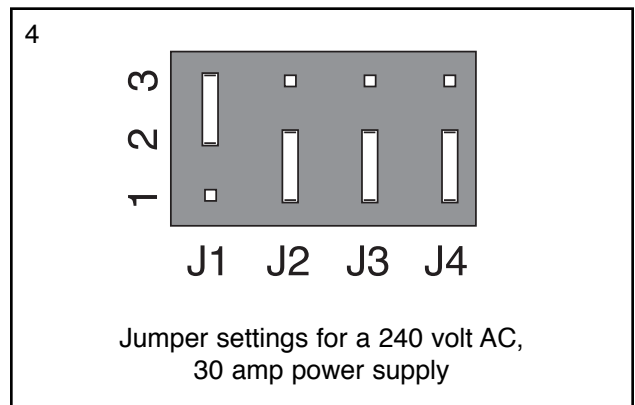

- For a 40 amp 240 volt AC power supply, set the jumper J1 to pins 1 and 2 on the power board and leave the other jumpers at the factory settings, as shown at the right. This will allow the heater and the pump to operate at high speed simultaneously.

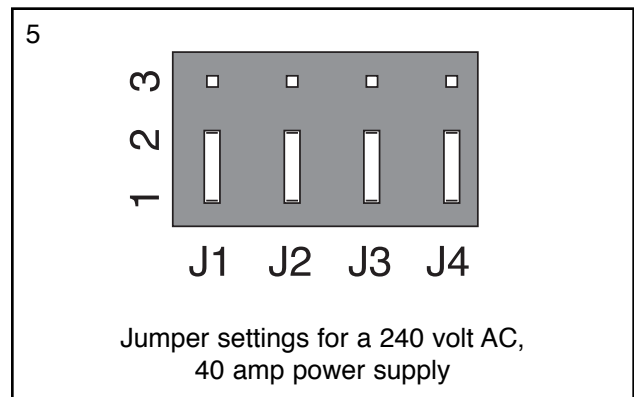

- Secure the power cord by tightening the screws in the wire clamp on the Control Unit (14).

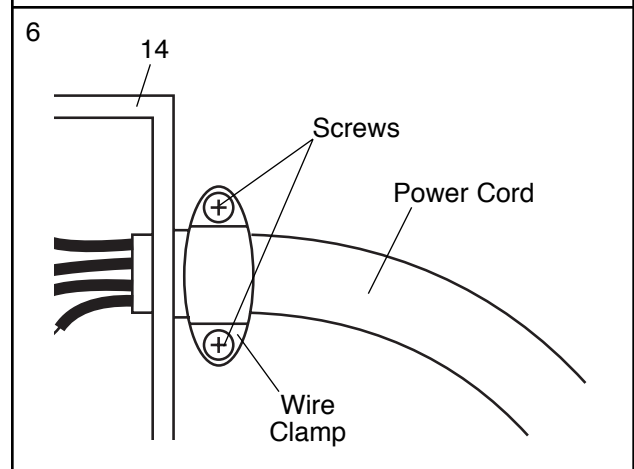

- Close the cover on the Control Unit and secure the cover with the two Control Unit Screws and the two Small Star Washers removed in step 1.
- Install the 240 volt GFCI at the source voltage to conform with national electrical codes.
- Attach the power cord to the 240 volt AC power source. Be sure that the 240 GFCI is in place.
- Test the GFCI for proper operation.

- Attach the access cover to the Spa Unit (15) by inserting the top of the cover under the edge of the spa shell. Be sure the 240 volt power cord is routed through the notch in the cover. Slide the cover into place and secure the cover with the four access cover screws.

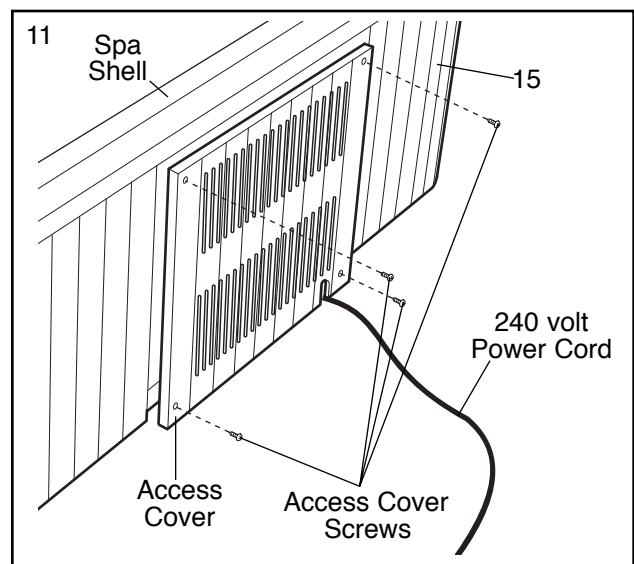

USING THE HYDROTHERAPY SPA

The hydrotherapy spa is designed to seat five adults. The fifteen thera-jets can be regulated to provide a relaxing massage to sooth away stress, and the strength of the water massage can be adjusted by the air control. The hydrotherapy spa holds 200 gallons of water and offers an automatic, programmable heating (41°F to 104°F) and filtration system.

The guidelines below explain how to properly use the hydrotherapy spa. Follow these guidelines to maintain the hydrotherapy spa for your long-term enjoyment.

STARTING THE HYDROTHERAPY SPA

Start the hydrotherapy spa by pressing the pump button on the console; you should verify the water flow from the pumping unit. Set the air control on the console to the lowest setting (see USING THE CONSOLE on page 14). The heat control unit will heat the water as it is pumped. Cover the hydrotherapy spa with the spa cover. **The spa cover must be tight.** (See SECURING THE SPA COVER on this page.) The water will heat at 6.0 to 8.0°F an hour with the cover on. If you are using the spa indoors, and the room temperature is maintained at 70°F, it will take approximately 5 to 7 hours for the water to reach the set temperature.

The temperature and water flow can be set or changed by the controls on the console (see USING THE CONSOLE on page 14).

TESTING AND TREATING THE WATER

The hydrotherapy spa comes with a starter chemical pack for maintaining the water in the spa. Disregard the directions on the individual packages of “QUICK pHix It DOWN” and “QUICK pHix It UP.” However, the directions on the bottle of “Non-chlorine Shox” and “Bromine Base” are correct. **Always keep the chemicals away from children and pets.**

The first time you use the spa, you should test and treat the water. **You must also treat the water each time you refill the spa.** Once you have verified that the spa is functioning properly, and the water has circulated for a while, remove the spa cover and add 1/3 of the “Bromine Base” bottle, and 1/3 of the “Non-chlorine Shox” bottle to the water. Allow the water to circulate for five minutes. You should now test the pH of the water. You will need a pH test kit (not included), which can be obtained at a pool and spa supply store. The pH reading should be between 7.2 and 7.8.

If the level is too low, add half of one of the “QUICK pHix It UP” packets to the water. Let the water circulate through the spa for five minutes. Test the pH level again. Repeat until the pH level is correct.

If the level is too high, add half of one of the “QUICK pHix It DOWN” packets to the water. Let the water circulate through the spa for five minutes. Test the pH level again. Repeat until the pH level is correct.

See WATER CHEMISTRY on page 17 for information concerning proper water maintenance.

SECURING THE SPA COVER

The spa cover can be secured by snapping the latches on the spa cover into the buckles on the side panels.

The buckles can be locked by inserting the key and turning it clockwise a quarter turn. To unlock the buckles, insert the key and turn it counter-clockwise a quarter turn.

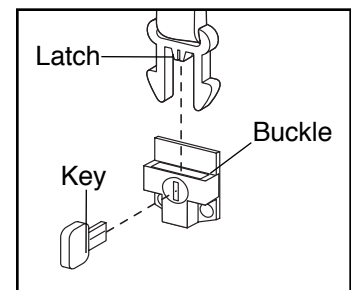

Always keep the buckles locked when the spa is not in use. Keep the keys in a safe place, out of the reach of children.

ATTACHING THE RED AND BLUE LIGHT COVERS

The RESTORATION 5.1 comes with two colored covers for the spa light. To attach the red or blue light cover to the light, place the desired cover over the light and press the cover into place on the light.

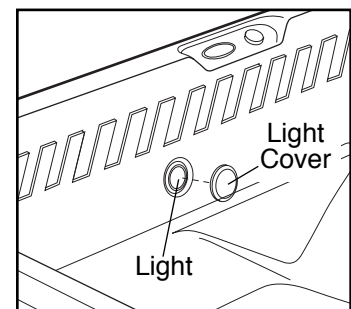

SPA SHELL DIAGRAM

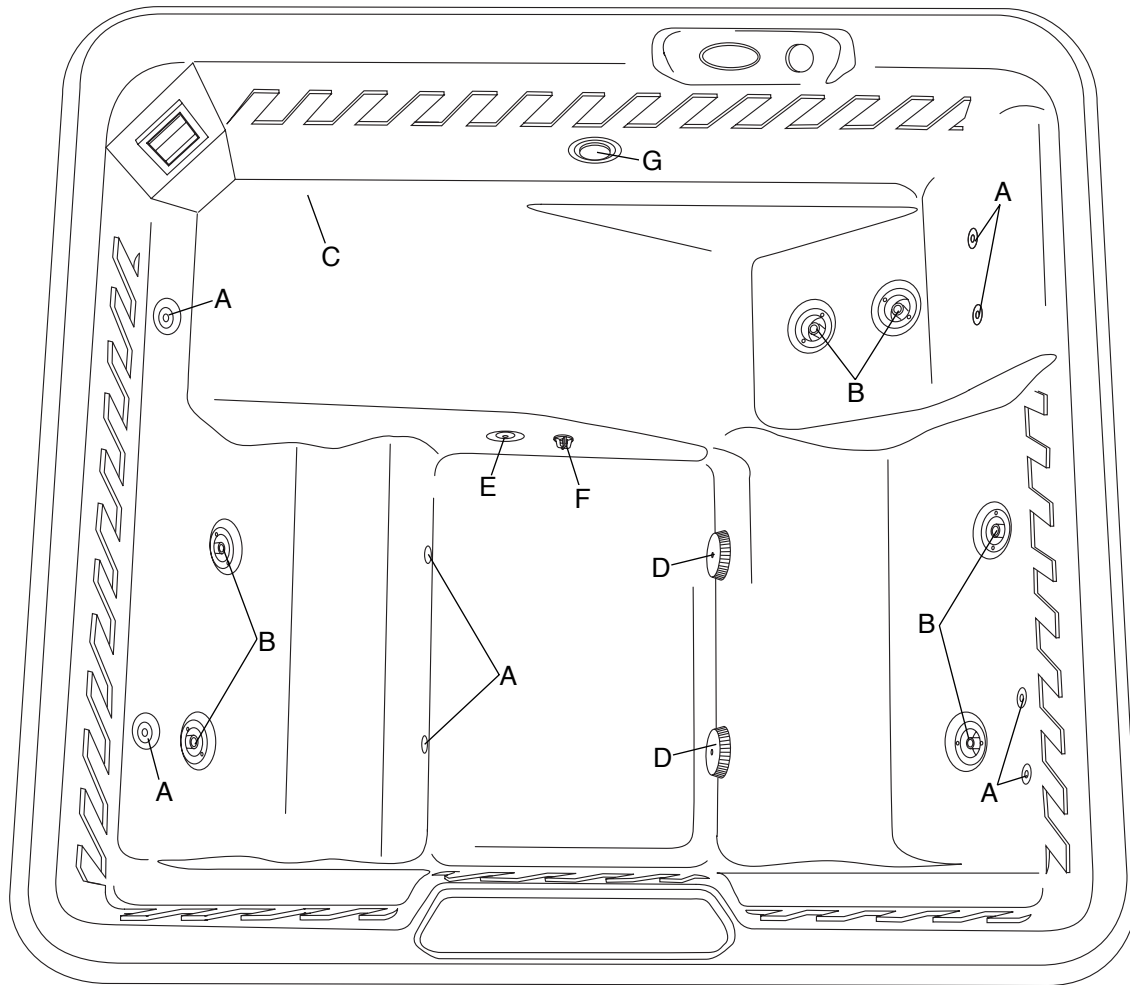

SPA OPERATION

Refer to the diagram above. The function of each component is explained below:

The **eight uni-directional thera-jets (A)** are located on both sides of the spa. Five jets focus the water massage on your upper or lower back. The remaining three jets provide a foot hydro-massage for three of the seating positions.

The **six multi-directional thera-jets (B)** can be adjusted for a custom hydro-massage. Each thera-jet can also be shut off by being pressed in and turned back on by pulling the jet back out. Two of the jets are located on the reclining seat and focus the water massage on your lower back. Two more jets are located on each of the bench seats, and focus the water massage on your lower or middle back.

The **filter (C)** can be removed for replacement and cleaning (see CHECKING AND CLEANING THE FILTER on page 19).

The **suction vents (D)** located near the floor of the spa brings the water into the pump in order to operate the system. The suction covers should always be in place over the suction vents. **Never operate the spa without the suction covers in place.**

This spa is ozone ready. An optional ozone generator can be installed to utilize the **ozone jet (E)**. Ozone provides a way to help sanitize your spa with minimal chemical treatment.

The temperature probe (F) reads the current water temperature, which is displayed on the console.

The RESTORATION 5.1 also has a light (G) for your safety and convenience during evening use.

The RESTORATION 5.1 features automatic freeze protection. If the water temperature falls below 40°F, the pump will begin circulating and heating the water to prevent the water from freezing.

CONSOLE DIAGRAM

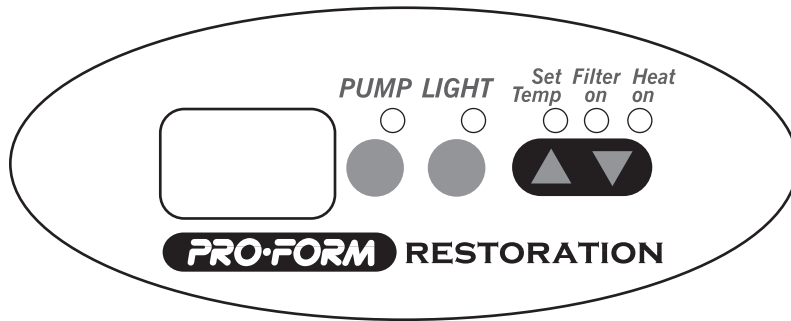

USING THE CONSOLE

Refer to the console diagram above. The function of each console control is explained below:

Temperature Display: During normal use this display shows the actual water temperature. When the Set Temp indicator is lit, the display shows the set temperature.

Light: This button turns the light on and off. When the light is on, the indicator above the light button will be lit. The light will automatically turn off after two hours.

Pump: This button turns the pump on and off. When the pump is running, the LED indicator above the button will light. To turn the pump on high, press the button once. The thera-jets will operate at full speed. To turn the pump on low, press the control twice. The thera-jets will operate at low speed. After you press the button a third time, the thera-jets will shut off, unless it is time for the heat or filter cycles. If you turn the pump off and it continues to operate, check if the Heat On or Filter On indicators are lit to see if either cycle is running.

Set Temp: This indicator will light when the temperature is adjusted by using the up and down buttons. To adjust the temperature, press either the up or down buttons to select a new temperature. The thermostat can be set to heat the water from 41°F to 104°F. While you are setting the temperature, the temperature display will show the new temperature. The new temperature will remain in the display for five seconds after you release the buttons. Then the Set Temp light will turn off and the display will return to the actual water temperature. The water heats at 6.0 to 8.0°F per hour with the cover on.

Heat On: This LED indicator is lit when the spa is running the heating cycle.

Filter On: This LED indicator is lit when the spa is running the filter cycle.

Note: To keep the heat and filter cycles from running, shut off the circuit breaker or GFCI.

Air Control: Determines the amount of air that is in the spa jet system during operation. If the control is turned to the left, the amount of air flowing through the jets will increase. If the control is turned to the right, the amount will decrease.

Error Messages: When certain problems occur, the Temperature Display will show an error code. The error codes are explained below:

- HL** High temperature protection mode. If the water temperature rises above 115°F, the heater will shut off. If the temperature rises above 122°F, the high temperature circuit will shut off the entire system. In either case, once the water has cooled to normal, you can press any button to reset the system.
- FrE** Freeze protection mode. If the water temperature falls below 40°F, the pump will begin cycling the water through the heater to raise the temperature. This cycle will run for one minute and may be repeated as needed.
- FLC** Flow related problems. You will need to call our customer service department.
- FLO** Flow related problems. You will need to call our customer service department.
- PrH** High temperature probe problem. You will need to call our customer service department.
- Prr** Temperature probe problem. You will need to call our customer service department.

ADJUSTING THE FILTER CYCLE

The spa filter cycle runs automatically to clean the water in the spa. However, the number of times that the filter cycle needs to run depends on how often the spa is used.

If many different people use the spa regularly, then the water will need to be filtered more often than if it is only used occasionally by a few. The number of daily cycles, as well as the length of the cycle can be adjusted.

The pump can run one to three filter cycles daily. To change the number of cycles, press the pump and up buttons at the same time. The number of cycles will appear in the temperature display. Use the up and down buttons to select the desired number of cycles.

Each cycle can run for 60, 120, or 180 minutes. To change the length of the cycle, press the light and up buttons at the same time. The length of the cycle will appear in the temperature display. Use the up and down buttons to select the desired cycle length.

The pump or the light may turn on while you are adjusting the filter cycle. If this happens, you can turn the pump or light off once you have finished the adjustment procedure.

POSTING THE WARNING SIGN

The warning sign, shown below, must be posted on a wall or fence, where all users of the RESTORATION 5.1 will be able to see it. Whenever the spa is moved, the sign must also be moved and reposted near the spa.

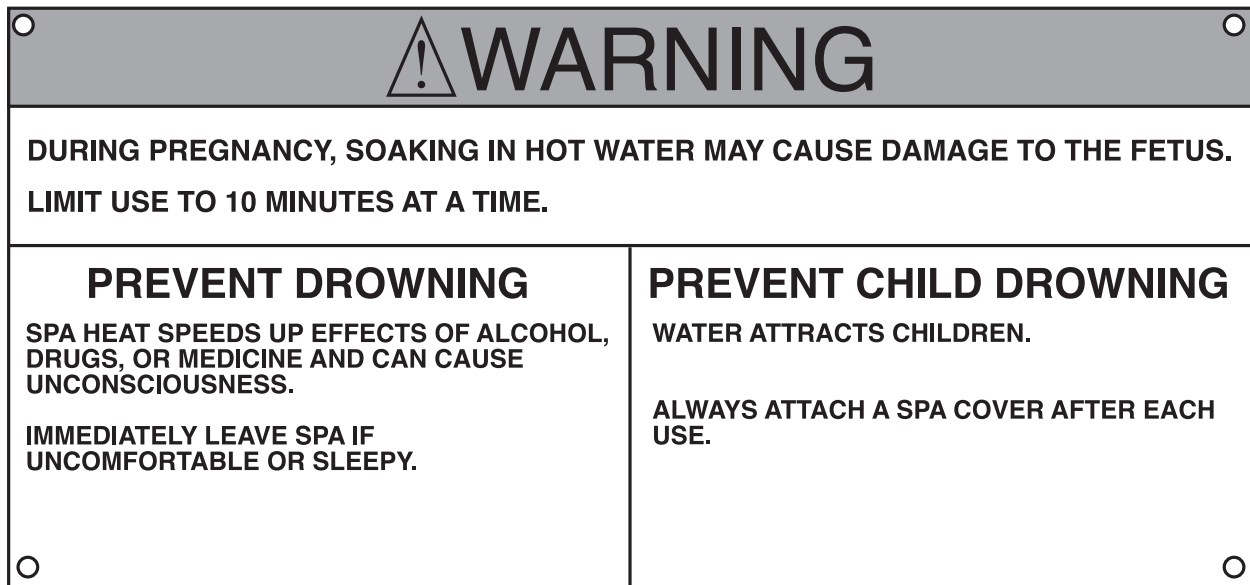

MAINTENANCE

The hydrotherapy spa is designed to provide you with years of enjoyment. Please follow the guidelines below to properly maintain your hydrotherapy spa.

MAINTENANCE SCHEDULE

DAILY

- Check the water level and refill the spa to the level shown on page 9, step 5.
- Check the pH balance and sanitizer level. Adjust if necessary (see WATER CHEMISTRY on page 17).
- Clean the surface of the water with a skimming net.

WEEKLY

- Clean the spa shell at the waterline.
- Check and thoroughly clean the filter (see CHECKING AND CLEANING THE FILTER on page 19).
- Replace the filter if needed (see ORDERING REPLACEMENT PARTS on the back cover).

MONTHLY

- Clean the spa cover (see MAINTAINING THE SPA COVER below).
- Soak the filter for two hours in a trisodium phosphate (TSP) solution. Rinse the filter in clean water.
- Replace the filter if needed (see ORDERING REPLACEMENT PARTS on the back cover).

EVERY THREE MONTHS

- Drain the spa and refill with clean water. Sanitize and test the pH of the water.
- Check for any leaks around the pump or joints in the pipes. The seals will wear out over time; detecting leaks early can reduce repair costs.
- Clean the interior of the spa. Do not use solvents or waxes.

EVERY SIX MONTHS

- Treat the exterior with a wood sealant (see MAINTAINING THE SPA EXTERIOR below).

MAINTAINING THE SPA EXTERIOR

The wood panel exterior has been treated with a sealant at the factory to protect the wood from water damage. We suggest that you treat the wood finish twice a year with an additional coat of weather sealant. Contact your local spa and pool supplier for advice on which sealants work best in your climate.

CLEANING THE SPA SHELL

The spa shell should be cleaned with a mild soap solution. Do not use solvents. The spa should always be clean and dry before being moved or stored.

MAINTAINING THE SPA COVER

The spa cover should be cleaned monthly. To clean the spa cover, use water and a non-abrasive cleaner on the entire cover. Rinse the cover with a garden hose to remove any cleaner residue. Dry the cover entirely. You should also use a non-silicone based vinyl conditioner on the cover after you clean it. This will help protect the cover from sun damage.

REPLACING THE LIGHT BULB

If the light in the spa shell burns out, you will need to remove the access cover to replace it (see ATTACHING AND REMOVING THE ACCESS COVER on page 17).

Locate the light housing. Turn the housing counter-clockwise and remove it from the spa shell.

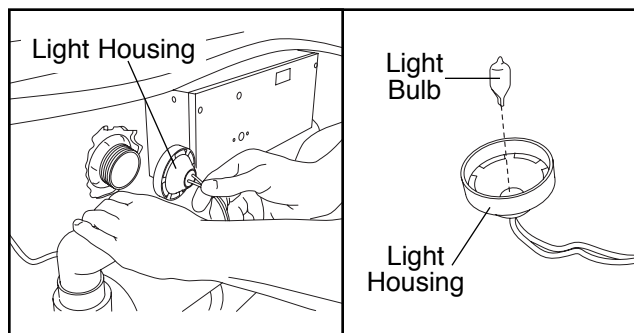

To replace the light bulb, pull the old bulb out of the housing and insert a new light bulb. Re-attach the light housing to the spa shell. Re-attach the access cover to the spa unit.

SANITIZING THE HYDROTHERAPY SPA

Please refer to your local pool and spa supplier for information concerning which chemicals you should use in your area to sanitize the spa.

The most common sanitizing agent is a solid bromine concentrate. The amount required varies according to several factors, such as user load, temperature, water conditions, and so forth.

Proper water maintenance is a fairly complex process. We recommend that you contact your local pool and spa supplier for information on how you should best accomplish this.

WATER CHEMISTRY

The hydrotherapy spa comes with a starter chemical pack for maintaining the water in the spa. (See TESTING AND TREATING THE WATER on page 12.) Additional chemicals can be purchased at a pool and spa supply store.

CAUTION: The chemicals used to maintain the pH balance of the water and to sanitize the water can be dangerous. Always follow these basic guidelines when handling the chemicals:

1. Always read and follow the directions on the label, unless directed otherwise.
2. Never mix different chemicals.
3. Do not exceed the recommended amounts of chemicals—follow the directions on the label closely.
4. Keep all chemicals out of the reach of children and pets.
5. Keep all containers closed tightly when not in use.
6. Never add water to the chemicals—always add the chemicals to the water as directed.
7. Always store chemicals in a cool, dry place.

MAINTAINING THE PROPER PH BALANCE

The pH factor is a measure of relative acidity or alkalinity in the water. It is measured on a scale of 1 to 14. Pure water has a value of 7, which is neutral. Any value above 7 is alkaline, and any value below 7 is acidic. You should maintain a slightly alkaline pH level, between 7.2 and 7.8, in the hydrotherapy spa.

Severe problems can occur when the pH balance is not maintained within this range. If the pH level exceeds 7.8, dissolved minerals can build-up and clog the plumbing in the spa jet unit. If the pH level falls below 7.2, the acid level in the water will begin to corrode the metal parts in the spa jet unit. Also, the sanitation agents in the water will not be effective if the pH level is not properly maintained. Damage caused by improper pH levels is not covered under the warranty.

To maintain the proper pH level, you should test the pH of the water regularly. You will need a pH test kit (not included), which can be obtained at a pool and spa supply store. The pH reading should be between 7.2 and 7.8. If the level is too low, add a pH increaser (usually soda ash). If the level is too high, add a pH reducer (usually sodium bisulfate). Test the water again after five minutes. See the instructions with your pH test kit for additional information about testing and adjusting the pH.

ATTACHING AND REMOVING THE ACCESS COVER

To remove the access cover, remove the four access cover screws from the access cover. Slide the access cover down and pull the bottom of the access cover away from the Spa Unit. **Be careful not to damage the spa shell as you remove the cover.**

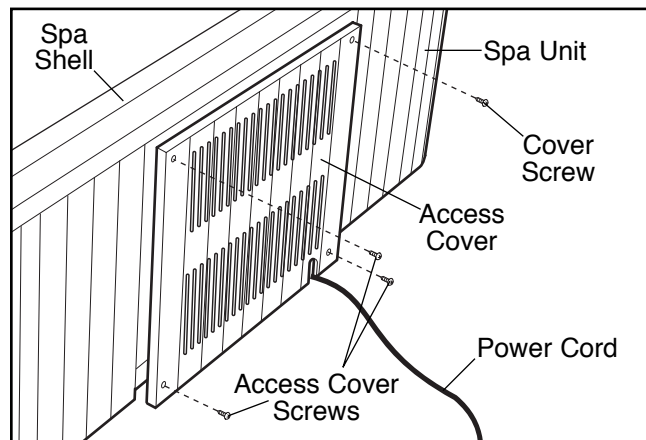

To replace the access cover, insert the top of the cover under the edge of the spa shell. Slide the cover up until the bottom of the cover will clear the trim along the bottom of the spa unit. Slide the cover into place and re-attach the four cover screws.

If you will be storing the spa for any period of time, a qualified electrician will need to disconnect the power cord from the 240 volt power source. You should place the power cord inside the spa unit before re-attaching the access cover.

DRAINING THE HYDROTHERAPY SPA

The hydrotherapy spa should be drained at least four times a year and refilled with clean water. You may need to drain the spa more often, depending on the user load. This must be done, because after repeated chemical treatment, the water becomes chemically saturated. Once this happens, additional chemical treatment of the water is no longer effective. The spa should also be drained if you will not be using it for long periods of time. The spa must always be drained before major repairs are made.

The hydrotherapy spa should always be covered when it is empty. Direct sunlight can cause extensive damage. The surface of the spa shell can reach temperatures as high as 150°F in a matter of minutes if exposed to the sun while it is empty. These high temperatures can cause significant damage, such as blistering of the shell surface and warping of the spa shell. Any damage caused by sun exposure is not covered under warranty.

To drain the hydrotherapy spa, follow these steps:

1. Set the temperature control on the console to the lowest setting.
2. Shut off the circuit breaker or GFCI.
3. Remove the access cover from the back of the spa unit.
4. Remove the drainage hose from the clip and attach a garden hose to the valve on the drainage hose.

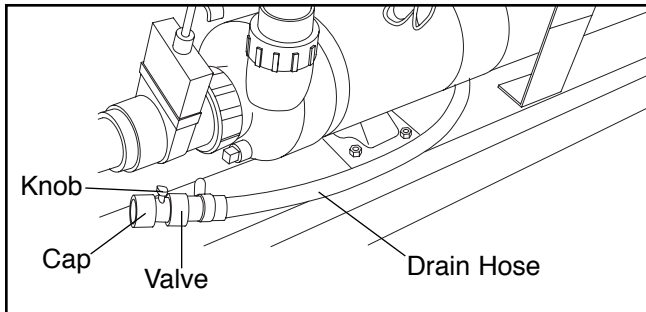

5. Open the valve by turning the knob counterclockwise. The water will begin to drain.
6. When the spa is empty, close the valve and remove the garden hose. Return the drainage hose to the clip and replace the access cover.
7. Refill the spa and treat the water with chemicals (see pages 9, 12 and 17).

DRAINING THE PUMP

After the hydrotherapy spa is drained (see DRAINING THE HYDROTHERAPY SPA on page 17), the pump in the spa jet unit should also be drained if the hydrotherapy spa will be stored for more than thirty days, or if it may be exposed to freezing temperatures.

To drain the pump, remove the access cover from the spa unit (see ATTACHING AND REMOVING THE ACCESS COVER on page 17). Locate the pump inside the spa unit.

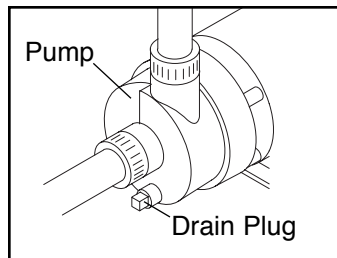

Remove the drain plug from the pump. Tip the spa jet unit slightly, until all the water has drained from the pump. Replace the drain plug.

OPENING AND CLOSING THE CUT-OFF VALVES

For minor repairs to the pump/motor, the cut-off valves can be closed. To close the valves, remove the access cover from the back of the spa unit. Locate both cut-off valves. Push the handles into the closed position and turn the handles until they lock into place.

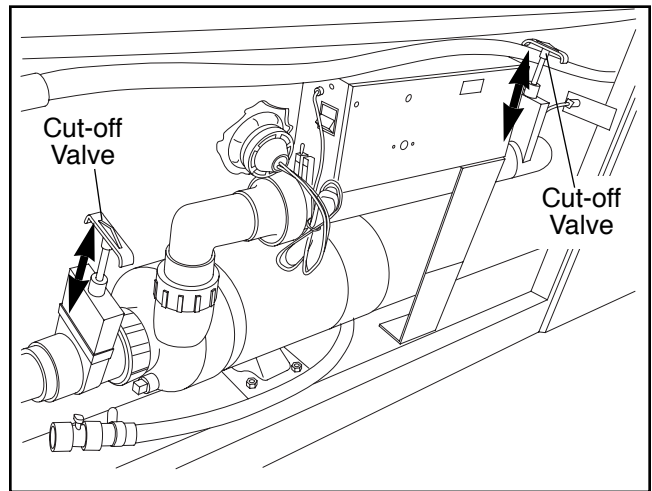

If you are planning to work on the pump/motor, you will also need to drain the pump (see this page).

To open the valves, turn the handles until they are unlocked, and pull the handles out to the open position.

WINTER USE AND CARE

The hydrotherapy spa is designed for year-round use. If you decide to store the hydrotherapy spa for the winter, store it in a warm, dry location. Follow the steps below to winterize the hydrotherapy spa.

1. Drain the spa (see DRAINING THE HYDROTHERAPY SPA on pages 17 and 18).
2. Remove all remaining water from the spa shell. Dry the spa shell with towels.
3. Set the air control on the console to the lowest setting. Use a wet/dry vacuum to pull any remaining water from the system. To do this, place the vacuum nozzle over each thera-jet, starting with the highest jet and finishing with the lowest one.
4. Set the air control on the console to the highest setting and repeat step 3.
5. Drain the pump (see DRAINING THE PUMP on page 18). Once the water has drained from the pump, place the vacuum nozzle over the drainage hole in the pump and vacuum any additional water from the pump. **Note: For additional protection you can remove the pump/motor from the spa to store it in a climate controlled room.**
6. Clean the spa shell (see page 16).
7. Clean the filter (see page 19).
8. A qualified electrician should disconnect the power cord from the 240 volt power source.
9. Re-attach the access cover and re-attach the spa cover.

CHECKING AND CLEANING THE FILTER

The filter should be checked periodically for build-up of dirt and oil. To check or clean the filter, it is necessary to remove the basket and the two filter cartridges from the filter housing.

Removing and Cleaning the Basket:

1. Turn off the power.
2. Pull the weir door towards you until it is fully open.
3. Reach into the basket with four fingers and pull the basket towards you until it snaps free.
4. Lift the basket out of the housing by pulling on the handle on the far side and turning the basket towards you.
5. Clean the basket by spraying it with a garden hose or holding it under a faucet. **Note: Avoid hitting the basket against objects to clean it, since this may break the basket.**
6. Put the basket back into the housing and press down until it snaps into place.
7. Close the weir door.

Removing and Cleaning the Filter Cartridges:

1. Follow steps one through four above to remove the basket.
2. Reach into the housing and turn the valve on the diverter until it is fully open.
3. Stick two fingers into the holes in the diverter and lift the diverter and the top filter cartridge directly upwards until the edge of the diverter clears the housing. Then turn the diverter towards you and

pull it out. In this process, the diverter may come out of the filter cartridge. If so, reach into the housing and lift the filter cartridge out.

4. Lift the lower filter cartridge out of the housing.
5. Clean the filter cartridges with a garden hose or under a faucet. Spray from top to bottom of each pleat. **Note: To avoid damage to the cartridges, do not use a brush to clean them.**
6. To remove body oils or sun tan lotions, soak the cartridges in a cleaning solution which can be obtained from a pool and spa supply store.
7. Inspect the filter cartridges for damage. Replace the cartridge if there is any sign of damage.
8. Put one filter cartridge back in the filter housing.
9. Push the tube on the diverter into the other filter cartridge as far as it will go. Place the top filter cartridge back in the housing.
10. Put the basket back into the housing and press down until it snaps into place. Close the weir door.

ADJUSTING THE DIVERTER

The diverter regulates the flow of water to the filter in order to make the pump run smoothly. Start by leaving the valve wide open. If the pump runs smoothly, no further adjustment will be necessary.

If the pump begins to cavitate (if you hear a cracking sound or if the speed of the pump surges up and down), turn the valve slightly to reduce water flow. Keep adjusting the valve in small increments until the pump runs smoothly.

TROUBLE-SHOOTING

Most problems can be solved by following the simple steps below. Find the symptom that applies, and follow the steps listed. If further assistance is needed, call our Customer Service Department toll-free at 1-800-999-3756, Monday through Friday, 6 a.m. until 6 p.m. Mountain Time.

1. SYMPTOM: THE SPA WILL NOT OPERATE

- a. Check to see if the GFCI breaker is tripped, or was not turned on. Reset the GFCI breaker.
- b. Make sure the Heater Switch (7), located on the Control Unit (14) inside the pump compartment, is in the "ON" position. **Note: The spa will not operate if the Heater Switch is in the "OFF" position.**

2. SYMPTOM: THE CIRCUIT BREAKER OR THE GFCI TRIPS WHILE THE SPA IS OPERATING

- a. Reset the circuit breaker or the GFCI. If the circuit breaker or the GFCI trips again, contact a qualified electrician for service.

3. SYMPTOM: THE PUMP HUMS

- a. The filter may be dirty or damaged. Remove the filter housing from the spa jet unit and clean or replace the filter.
- b. The pump may have a foreign object stuck in the impeller. Contact our customer service department.
- c. The pump may have a loose wire connection. Contact our customer service department.

4. SYMPTOM: THE PUMP HUMS BUT DOES NOT ROTATE

- a. The pump may be jammed. Contact our customer service department or, if your spa is no longer under warranty, you may also contact a local spa and pool service provider.

5. SYMPTOM: THE PUMP IS NOISY WHILE OPERATING

- a. There may be debris in the pump. Contact our customer service department.
- b. The pump may have a bad bearing. Contact our customer service department.

6. SYMPTOM: THE WATER DOES NOT HEAT

- a. Make sure that the hydrotherapy spa is fully covered with the spa cover. **The spa cover must be tight for the water to heat.** Set the air control to low. Set the temperature to the desired setting. The water will heat at 6.0 to 8.0°F an hour. If you are using the spa indoors, and the room temperature is maintained at 70°F, it will take approximately 5 to 7 hours for the water to reach the set temperature.
- b. If you are using the HYDROTHERAPY SPA outdoors, it may take longer for the water to heat. See the chart below for the approximate heating time.

<u>Air Temperature</u>	<u>Heating Time</u>
70°F +	5 to 7 hours
50°F–70°F	7 to 10 hours
30°F–50°F	10 to 15 hours

If the water still has not heated after four days, contact our customer service department.

- c. If actual water temperature is lower than the set temperature, and the **Heat On** LED indicator on the console is not lit, contact our customer service department.

7. SYMPTOM: THE WATER IS NOT BEING CLEANED BY THE FILTER

- a. Check to see if the filter is in place. Clean the filter if it is dirty.
- b. Check the chemical balance of the water. If the pH is incorrect, the sanitizing agents will not function properly.

8. SYMPTOM: THE WATER PULSATES OR THERE IS MINIMUM WATER FLOW

- a. Adjust the water level. This usually occurs only when the water level is low. Add water until the thera-jets are covered (see step 5 on page 9).

9. SYMPTOM: THE WATER LEVEL DROPS

- a. Some water loss due to evaporation is normal. If rapid water loss occurs, or if you notice wetness on the floor around the hydrotherapy spa, then the spa shell may have a leak. Contact your local spa and pool service provider for repairs.
- b. A clamp or seal inside the pump compartment may be loose. Check inside the pump compartment for excess water, and watch the pump unit while it is operating to see if water drips from any of the plumbing. If you can identify the location of the leak inside the spa jet unit, tighten the clamp or replace the damaged seal.

10. SYMPTOM: THE SPA CONTINUES TO RUN AFTER IT HAS BEEN SHUT OFF

- a. To turn the spa jets on high, press the Pump button once. To turn the spa jets on low, press the control twice. To turn the spa jets off, press the control three times. The spa jets will remain off for three hours, at which time they will begin running the filter cycle. At any time after the spa jets has been shut off, the pump will begin cycling the water if the temperature falls below the minimum setting. **Note: If the water is already below the minimum setting, the pump will not shut off.**

PART LIST—Model No. 831.210051

R0698A

Key No.	Qty.	Description	Key No.	Qty.	Description
1	8	Buckle Screw	26	1	Red Lens
2	4	Buckle	27	2	Large Star Washer
3	6	Motor Screw	28	1	Console Wire Harness
4	4	Motor Washer	29	2	Wing Nut
5	4	Rubber Insulator	30	1	Console Bracket
6	1	Blue Lens	31	2	Cover Screw
7	1	Heater Switch	32	2	Suction Cover
8	4	Small Star Washer	33	2	1/4" Nut
9	1	Heat Sensor	34	6	Rubber Washer
10	2	Filter Cartridge	35	1	Rubber Gasket
11	1	Hose Cap	36	1	1/2" Elbow Pipe
12	1	Rubber Damper	37	1	2" O-Ring
13	1	Pump Motor	38	1	Weir Door
14	1	Control Unit	39	1	Foam, Weir
15	1	Spa Unit	40	1	Trim Plate
16	1	Console	41	1	Diverter Valve
17	1	Control Knob	42	1	Diverter
18	1	Spa Cover	43	1	Basket
19	4	Control Unit Screw	44	10	#8 x 1 1/2" Screw
20	2	Small Index Nut	#	4	Access Cover Screw
21	2	Adjustment Bracket	#	1	Access Cover
22	2	1/4" x 1/2" Screw	#	2	Key
23	2	Small Bracket Screw	#	1	Starter Chemical Pack
24	2	Sensor Fitting	#	1	User's Manual
25	6	Multidirectional Jet	#	1	Light Bulb

Note: “#” indicates a non-illustrated part. Specifications are subject to change without notice.

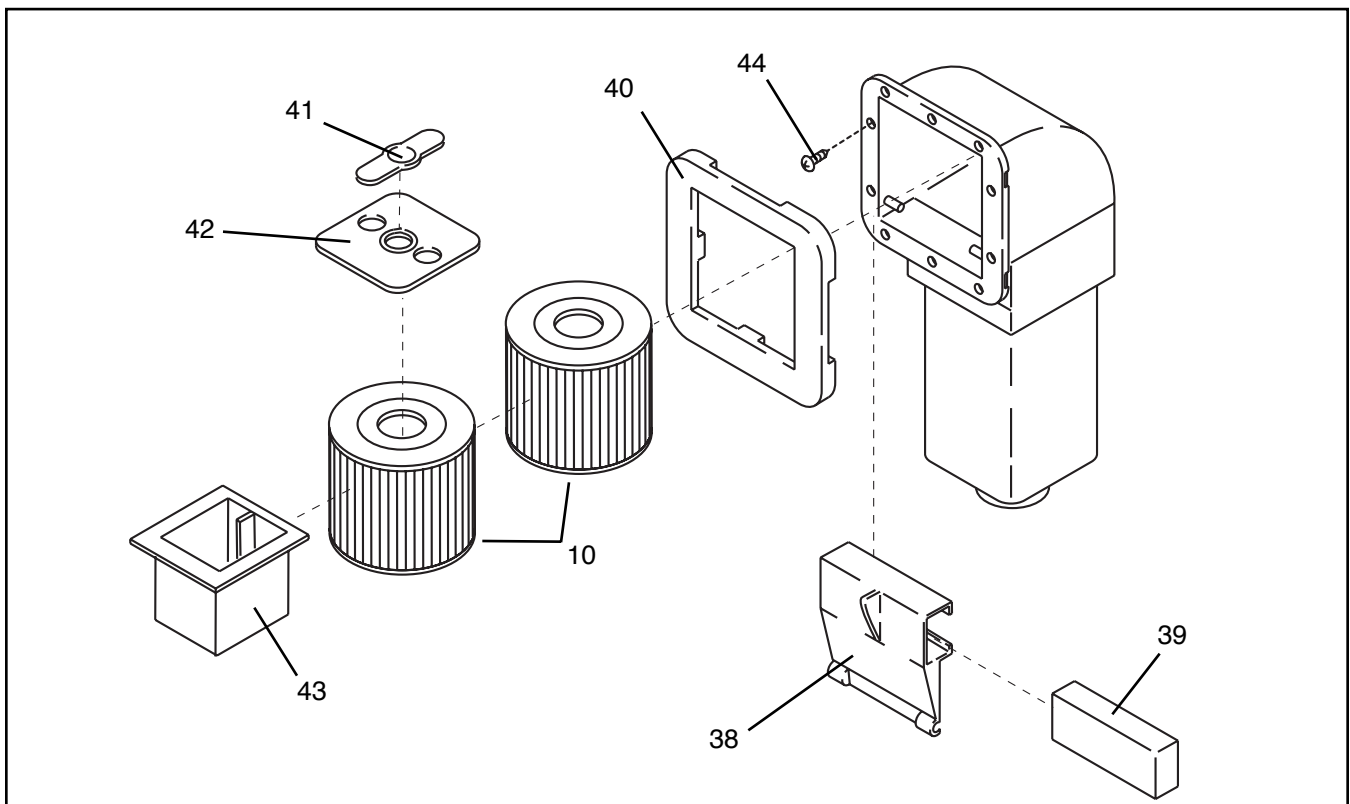

EXPLODED DRAWING—Model No. 831.210051

R0698A

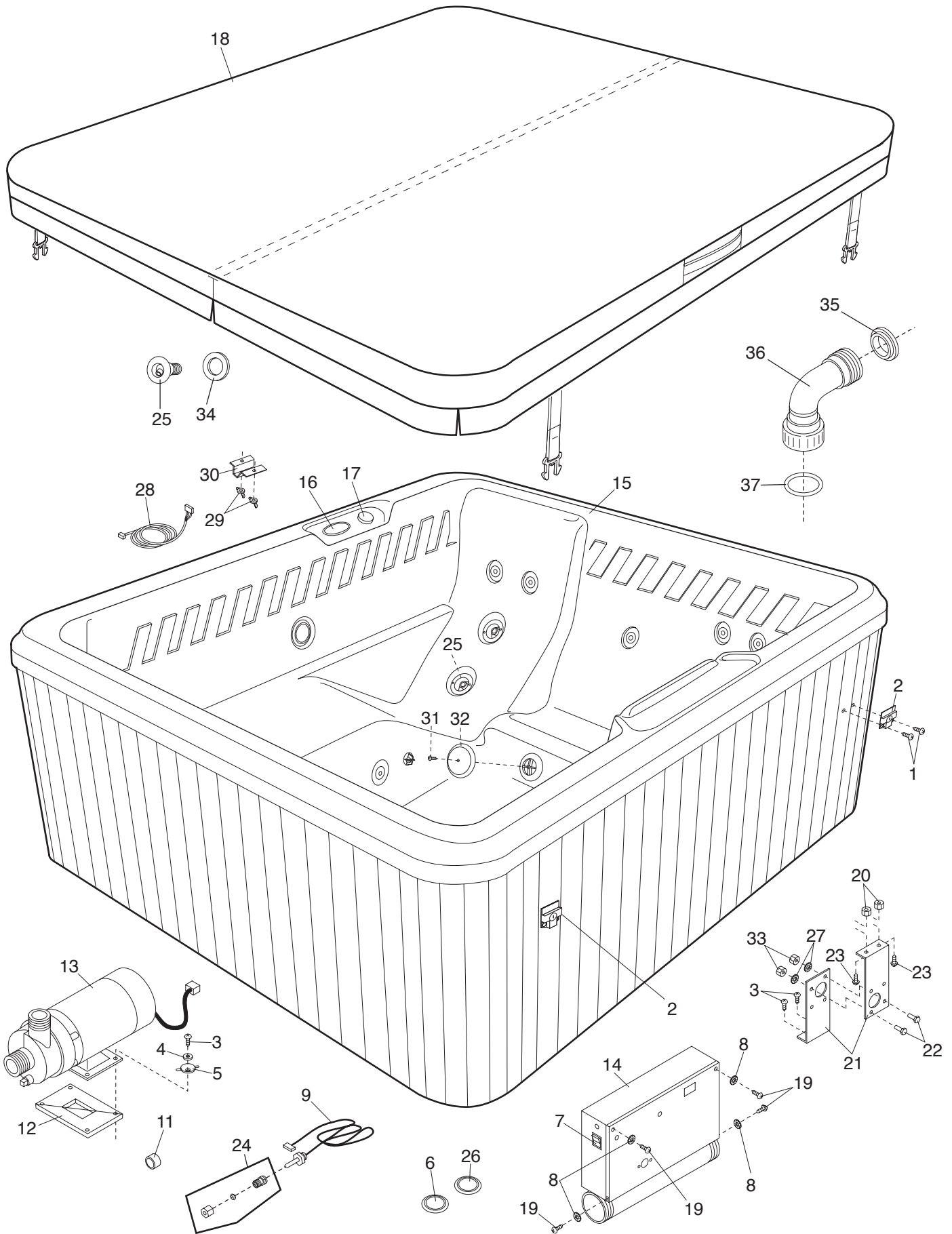

Model No. 831.210051

QUESTIONS?

As a manufacturer, we are committed to providing complete customer satisfaction. If you have questions, or find that there are missing or damaged parts, we will guarantee complete satisfaction through direct assistance from our factory.

TO AVOID UNNECESSARY DELAYS, PLEASE CALL DIRECT TO OUR TOLL-FREE CUSTOMER HOT LINE. The trained technicians on our customer hot line will provide immediate assistance, free of charge to you.

CUSTOMER HOT LINE:

1-800-999-3756

Mon.–Fri., 6 a.m.–6 p.m. MST

ORDERING REPLACEMENT PARTS

To order replacement parts, simply call our Customer Service Department toll-free at 1-800-999-3756, Monday through Friday, 6 a.m. until 6 p.m. Mountain Time (excluding holidays). To help us assist you, please be prepared to give the following information when calling:

1. The MODEL NUMBER of the product (831.210051).
2. The NAME of the product (PROFORM® RESTORATION 5.1).
3. The SERIAL NUMBER of the product (see the front cover of this manual).
4. The KEY NUMBER and DESCRIPTION of the desired part(s) (see the PART LIST on page 22 of this manual).

PROFORM® is a registered trademark of ICON Health & Fitness, Inc. The RESTORATION 5.1 is sold by SEARS.